

**STARBOARD
SIDE**

PORT SIDE

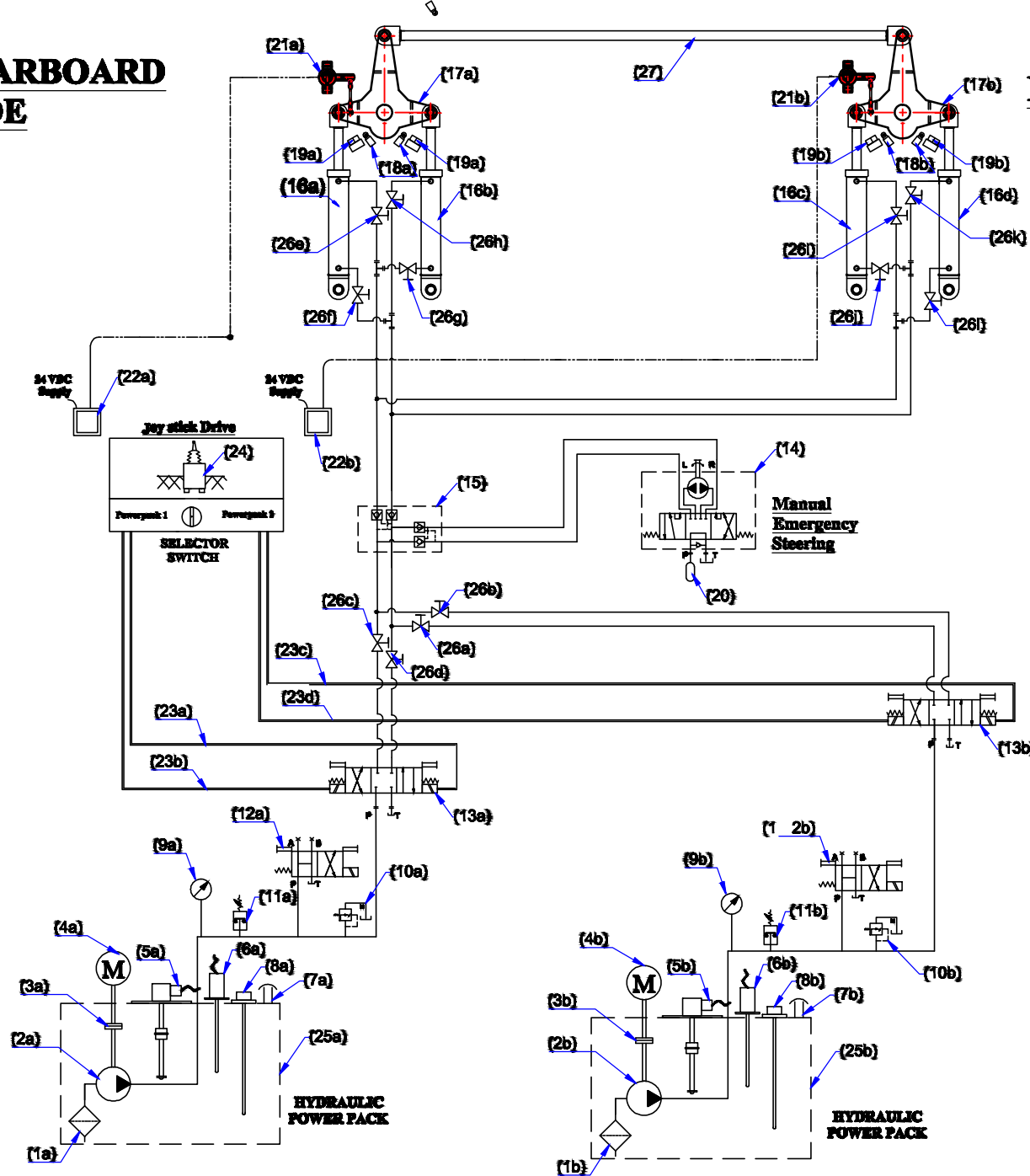

SI No.	Description
1a,1b	Suction Strainer
2a,2b	Hydraulic pump
3a,3b	Flexible Coupling
4a,4b	Elec. Motor
5a,5b	Oil Level Sensor
6a,6b	Oil Temp. Sensor
7a,7b	Filler Breather
8a,8b	Oil Dip Stick
9a,9b	Pressure Gauge
10a,10b	Pr. Relief Valve
11a,11b	Pre.Switch.Low Pre.Alarm
12a,12b	Unloading Valve
13a,13b	Sol. Oprtd. Dire. Control Valve
14	Emergency Manual Helm Pump
15	Pilot Operated Double Check Valve
16a,16b, 16c,16d	Hyd. Actuator - JumboZ 2800
17a,17b	Tiller Arm
18a,18b	Limit Switch
19a,19b	Mechanical Stopper- (Yard Supply)
20	Oil Reservoir
21a,21b	Rudder Angle Sensor
22a,22b	Rudder Angle Indicator
23a,23b, 23c,23d	Elec. Lines to Sol. Oprtd. Valve
24	Joystick
25a,25b 26a,26b, 26c,26d, 26e,26f, 26g,26h, 26i,26j, 26k, 26l	Isolation Valve
27	Connection Rod

ITEM	SCALE	MATERIAL	VIEW	DRAWN	CHECKED
/	/	/		AS	VUK
DESIGNATION			DRAWING NO :		QTY
Electro - Hydraulic Circuit JZ-2800E IRSx2			MHS-1260		/